



MBA

Adjusters - Rigid

Adjustable supports for all kinds of machinery

Mild steel bright zinc plated.

Screwdriver cross recess in base.

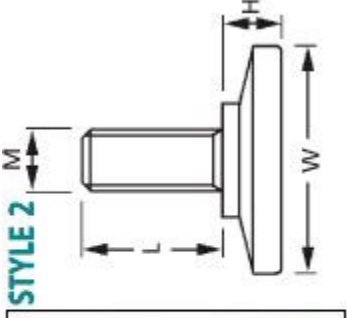
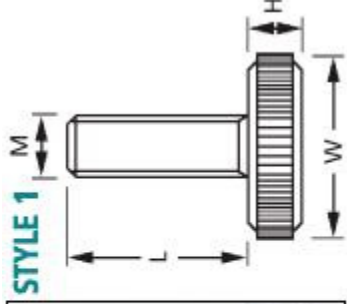

Adjusters - Rigid

| Part Number | Screw Size (MxL) mm | Base Diameter (W) mm | Base Height (H) mm | Max Static Load kg | Base Material | Style |
|-------------|---------------------|----------------------|--------------------|--------------------|---------------|-------|
| RAD5252-1 | M8 x 40 | 30.0 | 10.5 | 250 | Polyamide | 2 |
| RAD5249-1 | M8 x 25 | 30.0 | 10.5 | 250 | Polyamide | 2 |
| # RAD5253-1 | M8 x 40 | 40.0 | 10.5 | 250 | Polyamide | 2 |
| # RAD5250-1 | M8 x 25 | 40.0 | 10.5 | 250 | Polyamide | 2 |
| # RAD5254-1 | M8 x 40 | 50.0 | 10.5 | 250 | Polyamide | 2 |
| # RAD5251-1 | M8 x 25 | 50.0 | 10.5 | 250 | Polyamide | 2 |
| # RAD5210-1 | M10 x 40 | 30.0 | 9.0 | 500 | Polypropylene | 1 |
| # RAD5209-1 | M10 x 30 | 30.0 | 9.0 | 500 | Polypropylene | 1 |
| # RAD5278-1 | M10 x 40 | 30.0 | 10.5 | 250 | Polyamide | 2 |
| # RAD5275-1 | M10 x 25 | 30.0 | 10.5 | 250 | Polyamide | 2 |

E&OE Pricing and all details subject to change without notice - Copyright Miniature Bearings Australia Pty Ltd
MBA Size Listings are a guide to sizes only and must not be solely relied on for critical design information.

Adjusters - Rigid

| Part Number | Screw Size (MxL) mm | Base Diameter (W) mm | Base Height (H) mm | Max Static Load kg | Base Material | Style |
|-------------|---------------------|----------------------|--------------------|--------------------|---------------|-------|
| # RAD5279-1 | M10 x 40 | 40.0 | 10.5 | 250 | Polyamide | 2 |
| # RAD5276-1 | M10 x 25 | 40.0 | 10.5 | 250 | Polyamide | 2 |
| # RAD5280-1 | M10 x 40 | 50.0 | 10.5 | 250 | Polyamide | 2 |
| # RAD5277-1 | M10 x 25 | 50.0 | 10.5 | 250 | Polyamide | 2 |

E&OE Pricing and all details subject to change without notice - Copyright Miniature Bearings Australia Pty Ltd
MBA Size Listings are a guide to sizes only and must not be solely relied on for critical design information.

MBA **MINIAMNURD**
BEARINGS
 Australia Pty Ltd





















ABN 94 069 113 800

DISTRIBUTED BY

Ask us to put your name and address here

<http://www.minibearings.com.au/product>
 Ph +61 7 3349 1224
 Fax +61 7 3349 3801

Catalogue requests to catalogues@minibearings.com.au

| | | |
|---|---|---|
|  |  |  |
|  |  |  |
|  |  |  |
|  |  |  |
|  |  |  |
|  |  |  |